



VERSAs
ChILL

IM-350
ICE MACHINE

IM-350 CUBE ICE MACHINE



FEATURES

- CORROSION RESISTANT
- CONVENIENT, BUILT-IN SCOOP HOLDER
- ICE SCOOP INCLUDED
- EASILY REMOVABLE BAFFLE, NO TOOLS REQUIRED FOR CLEANING
- LIGHT WEIGHT
- ADJUSTABLE LEVELLING LEGS
- STANDARD CUBE ICE - 22MM X 22MM X 22MM
- ICE PRODUCTION - 350 LBS / 24 HRS
- STORAGE BIN CAPACITY - 300 LBS
- WATER FILTER INCLUDED
- COPPER NICKEL-PLATED EVAPORATOR PROVIDES MORE EFFECTIVE ANTI-CORROSION

WARRANTY:
THREE YEARS PARTS AND
LABOUR.
SPECIFICATIONS SUBJECT TO
CHANGE WITHOUT NOTICE.

FIND
ADDITIONAL
BENEFITS
HERE



ADDITIONAL IMAGES



MODEL DESIGNATIONS



ADDITIONAL RESOURCES

DIMENSIONS

MODEL		PRODUCT DIMENSIONS				SHIPPING DIMENSIONS			
		WIDTH	DEPTH	HEIGHT	WEIGHT LBS/KGS	WIDTH	DEPTH	HEIGHT	WEIGHT LBS/KGS
IM-350	INCH	22	33.8	68.7	207	36	36	73	207
	MM	558.8	858.5	1744.9	93.9	914.4	914.4	1854.2	68.0

TECHNICAL

CONDENSER UNIT	REFRIGERANT	AMPS	VOLTAGE	POWER	OUTPUT 24 HRS LBS/KGS	BIN CAPACITY LBS/KGS	 NEMA 5-15P
AIR-COOLED	R290	8.5	115/60/1	780W	350	300	
					159	136	
RECOMMENDED WATER TEMP	RECOMMENDED WATER PRESSURE	INLET PIPE DIAMETER	DRAIN PIPE DIAMETER	RECOMMENDED CLEARANCES			
>0.6°C ~ <32°C	>0.13 ~ <0.55	>9.5 MM	>15.8 MM	SIDE	BACK	FRONT	
>33°F ~ <89°F	(Mpa)	3/8"	5/8"	6"	8"	12"	

LINE DRAWINGS

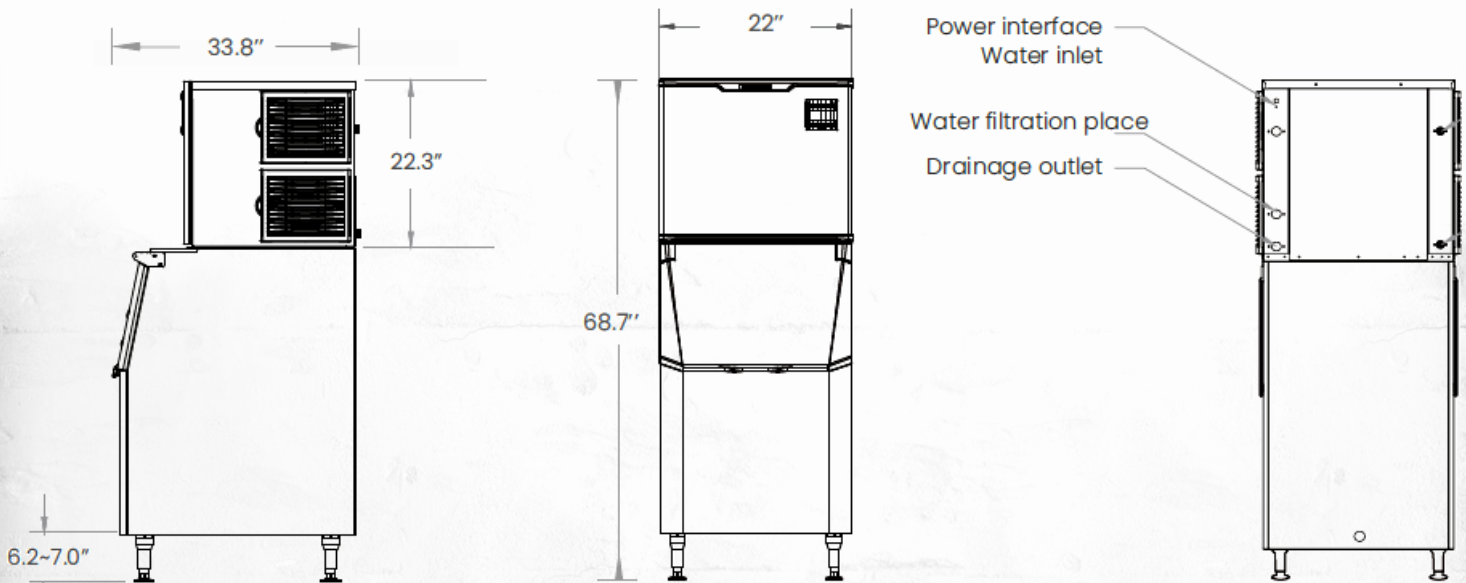

EFI Sales Ltd.
 Toronto Office & DC
 515 Hanlon Creek Blvd.
 Guelph, ON, N1C 0A1

EFI Sales Ltd.
 Vancouver Office & DC
 26895 Gloucester Way
 Langley, BC, V4W 3Y3

(888) 565-9920 Toll Free
 (519) 822-1895 Toronto
 (604) 607-8850 Vancouver